

# Cable

Floor Heating System

## INSTALLATION GUIDE

*July 2010 Edition*

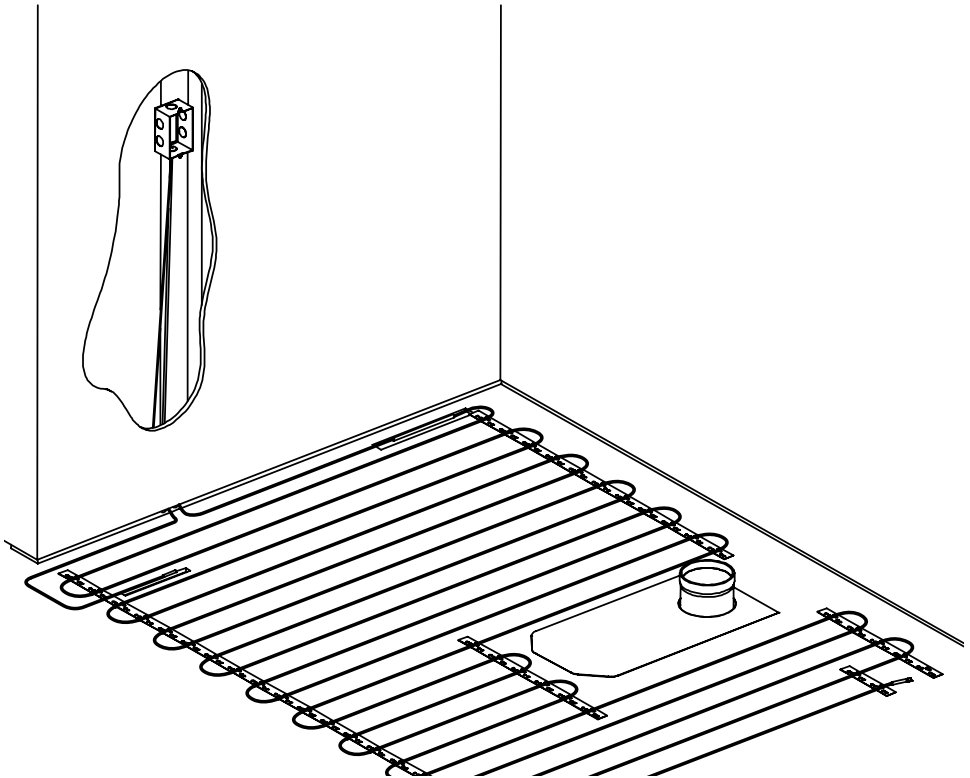

<b>1. Momento Cable Floor Heating System . . . . .</b>	<b>4</b>
1.1 General Information . . . . .	4
1.2 Always . . . . .	6
1.3 Never . . . . .	6
<b>2. Technical information . . . . .</b>	<b>7</b>
2.1 Surface Area and Power Output of <b>Momento Cable</b> Products .7	
2.2 Insulation Test . . . . .	8
2.3 Resistance Test. . . . .	9
<b>3. Types of Heating and Floor Covering . . . . .</b>	<b>10</b>
3.1 Floor Warming . . . . .	10
3.2 Radiant Floor Heating . . . . .	10
3.3 Typical Floor Coverings. . . . .	11
<b>4. Installation Instructions . . . . .</b>	<b>12</b>
4.1 Planning Work . . . . .	12
4.2 Preparing the Subfloor . . . . .	13
4.3 Marking the Floor. . . . .	13
4.4 Installing the <b>Momento Cable</b> Floor Heating System . . . . .	14
4.5 Installing the Temperature Sensor . . . . .	17
4.6 Applying Self-Levelling Cement . . . . .	18
4.7 Connecting the System. . . . .	19
4.8 Measuring Resistance and Measures' table . . . . .	20
4.9 Using the <b>Momento Cable</b> System . . . . .	20
<b>5. Temperature Regulation . . . . .</b>	<b>21</b>
<b>6. FAQ . . . . .</b>	<b>22</b>
6.1 Floor Heating System. . . . .	22
6.2 Installation . . . . .	22
<b>7. Expert Tips: Installation and Floor Covering. . . . .</b>	<b>24</b>
7.1 Installation Tips. . . . .	24
7.2 Floor Covering Tips. . . . .	24
<b>8. Warranty . . . . .</b>	<b>25</b>
8.1 Warranty Statement . . . . .	25

## 1.1 General Information



### IMPORTANT!

The installation must meet the following building codes, as applicable:

- Canadian Electrical Code (CSA C22.1)
- American National Electricity Code (ANSI/NFPA 70)
- Any other national or local code

The **Momento Cable** floor heating system is composed of a heating cable along with a lead for connection to an electrical power source. **Momento Cable** meets the following in The Canadian Electrical Code standard: series heating cables set.



### IMPORTANT!

Shut off power supply to the floor heating system to prevent electrical shock.

### Important informations

- The **Momento Cable** floor heating system is designed exclusively for interior floor heating. The system is not designed for snow melting or any other outdoor uses;
- **Momento Cable** is mainly designed to complement a building's primary heating source by serving as a secondary (floor warming) or primary room heat source (radiant floor heating);
- Refer to Section 3 for instructions on heating a room using the **Momento Cable** system only;
- Floor temperature varies based on insulation and floor characteristics;
- The **Momento Cable** system can be installed under a shower floor only if the floor is ceramic or natural stone. A waterproof membrane must be used to maintain the heating cables in a dry environment. **Canada:** A ground fault circuit interrupter (GFCI) must be used with this heating device in bathrooms. **USA:** A ground fault circuit interrupter (GFCI) must be used with this heating device in bathrooms and in hydromassage bathtub locations;
- The **Momento Cable** system must be embedded in cement or an equivalent binder (cement glue, ceramic glue or self-levelling cement);
- The system must be installed by a master electrician who is: able to evaluate proper electrical resistance and wattage, familiar with installation-related risks and knowledgeable about construction techniques as well as the installation and use of the **Momento Cable** floor heating system;
- The system is only one step in the floor construction process. Each trade is responsible for the quality of its work and must ensure that the work performed by the previous tradesman has been duly completed according to code. All tradesmen are engaged in the installation process and share joint responsibility for it.

## Components

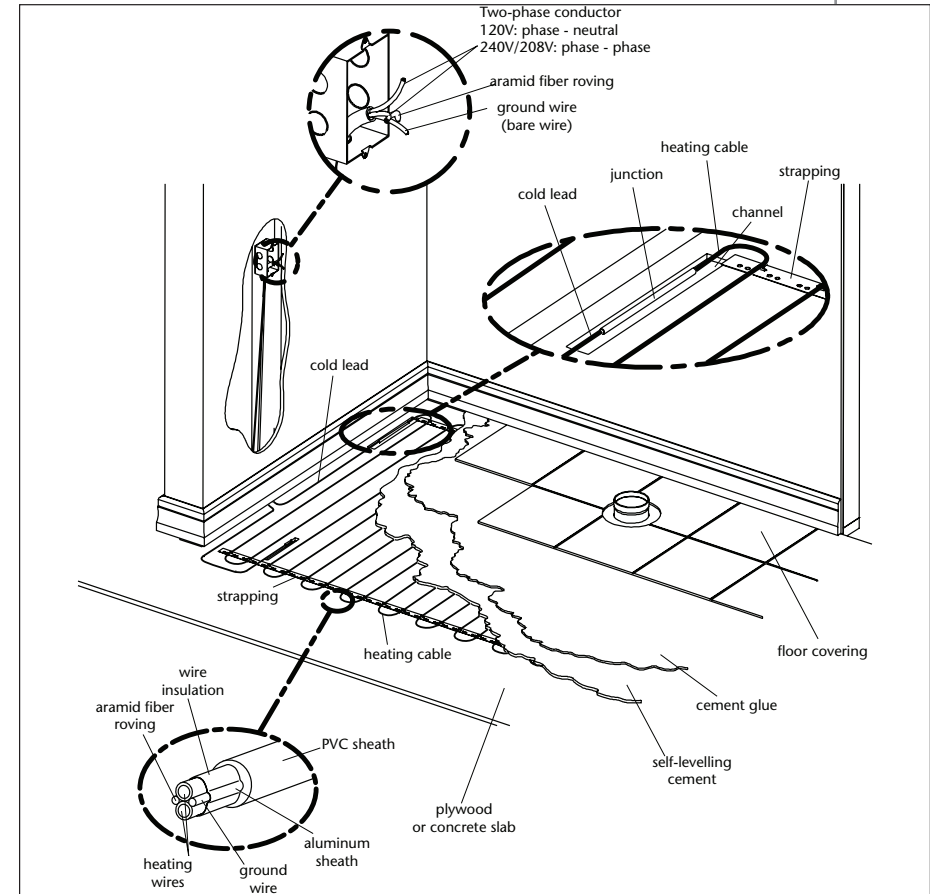

Fig. 1.1

### Technique for interlocking the plastic strappings

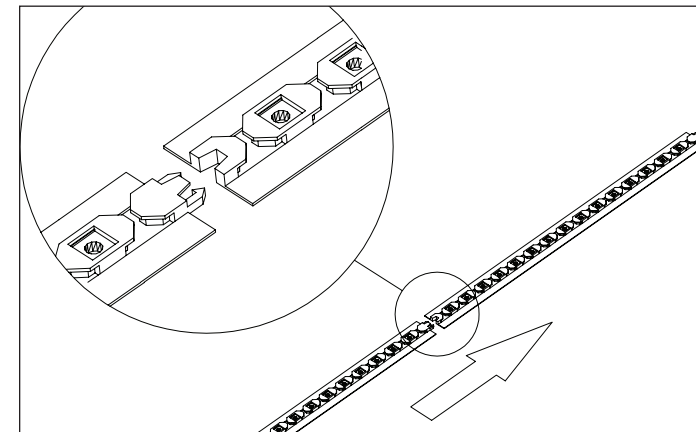

Fig. 1.2

## 1.2 Always

- Read this guide in full before installing the product;
- Install the **Momento Cable** system with a regulating device;
- Use copper wires only;
- Perform the mandatory tests described in this guide and record readings on the table of measures;
- Only use cement or an equivalent binder compatible with floor heating systems (cement glue, ceramic glue, self-levelling cement);
- Ensure that the black heating cable is completely embedded in cement or an equivalent binder (cement glue, ceramic glue, self-levelling cement);
- Ensure that the voltage supplied equals the nominal voltage of the **Momento Cable** system;
- Repair the product only using the **Momento Cable** repair kit available at your authorized CELSIAIR INC. dealer;
- Consult CELSIAIR INC.'s team of technical specialists for any questions or for more information;
- Install **Momento Cable** at temperatures over 5 °C (40 °F).
- Heating cables must be at least 13 mm (1/2") away from any combustible surface.
- Metal structures or materials used for the support of or on which cables or sets are installed be grounded in accordance with the Canadian Electrical Code (CSA C22.1 Section 10 and National Electrical Code).
- The installer of series heating cable sets must inspect and remove damaged or defective heating cable sets before they are covered or concealed;
- Installer of series heating cable sets must mark the appropriate circuit breaker reference (label) indicating which branch circuit supplies the circuit to those electric heating cables.

## 1.3 Never

- Install **Momento Cable** sections so that the heating cables are less than 76 mm (3") from each other. The temperature could be too high and could cause damages;
- Shorten or alter any part of the heating cable (Fig. 1.3);
- Cross, overlap, or stack heating cables (they must not touch);
- Connect a 120V product to a 240V/208V power source;
- Use a bending radius under 20 mm (3/4");
- Install a temperature regulator (thermostat or other) where it is accessible from the shower or bath (install at least 1 m [3' 4"] away);
- Staple heating cable or floor sensor end to the subfloor (Fig. 1.3);
- Install the **Momento Cable** system if the safety seal is broken;
- Install the **Momento Cable** system under a closet or fixed items.
- Series heating cable sets shall not extend from beyond the room or area in which they originate;
- Series heating cable sets are not to be installed in walls.

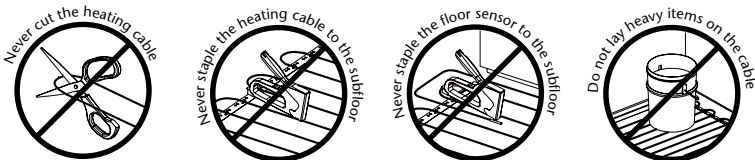

Fig. 1.3

## 2.1 Surface Area and Power Output of Momento Cable Products

Product # 120V	Length		Covered surface area		Power	Resistance
	ft.	m	sq. ft.	sq. m	Watts	Ohm
0085CAR120	32	9.75	8	0.7	85	169.4
0120CAR120	40	12.19	10	0.9	120	120.0
0150CAR120	52	15.85	13	1.2	150	96.0
0170CAR120	60	18.29	15	1.4	170	84.6
0240CAR120	80	24.38	20	1.9	240	59.9
0300CAR120	100	30.48	25	2.3	300	47.5
0360CAR120	120	36.58	30	2.8	360	39.6
0420CAR120	140	42.67	35	3.3	420	33.7
0475CAR120	160	48.77	40	3.7	475	29.8
0600CAR120	200	60.96	50	4.6	600	23.3
0720CAR120	240	73.15	60	5.6	720	19.0
0840CAR120	280	85.34	70	6.5	840	16.2
0960CAR120	320	97.54	80	7.4	960	14.2

Product # 240V/208V	Length		Covered surface area		Power	Resistance
	ft.	m	sq. ft.	sq. m	Watts	Ohm
0170CAR240	60	18.29	15	1.4	170	338.8
0240CAR240	80	24.38	20	1.9	240	240.0
0300CAR240	100	30.48	25	2.3	300	192.0
0360CAR240	120	36.58	30	2.8	360	159.8
0420CAR240	140	42.67	35	3.3	420	137.0
0475CAR240	160	48.77	40	3.7	475	121.1
0600CAR240	200	60.96	50	4.6	600	95.0
0720CAR240	240	73.15	60	5.6	720	79.2
0840CAR240	280	85.34	70	6.5	840	67.4
0960CAR240	320	97.54	80	7.4	960	59.0
1080CAR240	360	109.73	90	8.4	1080	51.8
1200CAR240	400	121.92	100	9.3	1200	46.6
1440CAR240	480	146.30	120	10.7	1440	37.9
1600CAR240	560	170.69	140	13.0	1600	34.1
1920CAR240	640	195.07	160	14.9	1920	28.4

208V = 75% of wattage at 240V.

## 2.2 Insulation Test



Measure **Momento Cable's** insulation resistance at each step using a megohmmeter (Fig. 2.2) and record readings on the measures' table (this label is available at the opening of the product).



### IMPORTANT!

For the warranty to be valid, fill out the measures' table and ensure that the 10 readings have been correctly noted.

A qualified electrician must measure the system's insulation resistance as follows:

- Use a calibrated megohmmeter only;
- Measure insulation resistance at the free end of the cold lead, between the phase conductor and ground;

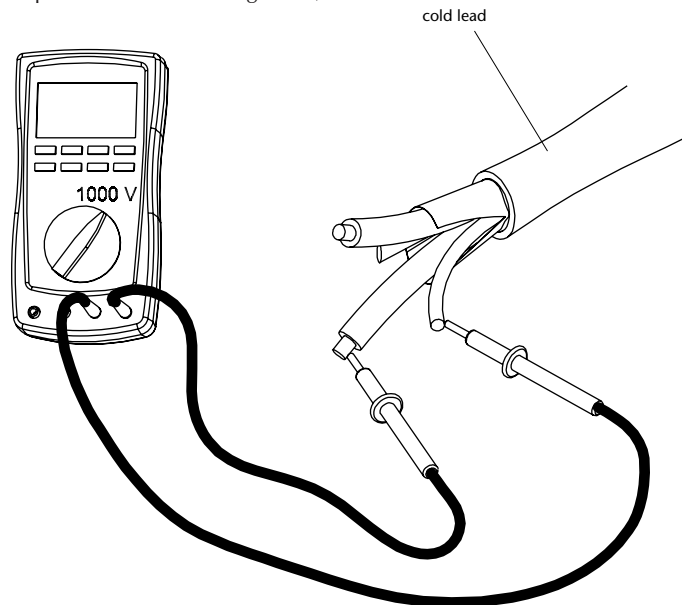

Fig. 2.2



### CAUTION! Dangerous Test

- Write the reading in the measures' table;
- This reading must be over 1,000,000 ohms;
- If the reading is under 1,000,000 ohms, stop work and contact CELSIAIR INC.'s technical specialists at 1 866 930-7878.

## 2.3 Resistance Test



Measure the resistance of the **Momento Cable** heating cable at each step using a multimeter (Fig. 2.3) and record readings on the measures' table.



### IMPORTANT!

For the warranty to be valid, fill out the measures' table and ensure that the 10 readings have been correctly noted.

A qualified electrician must measure the system's resistance as follows:

- Use a calibrated multimeter only;
- Measure resistance at the free end of the cold lead, between the two phase conductors;

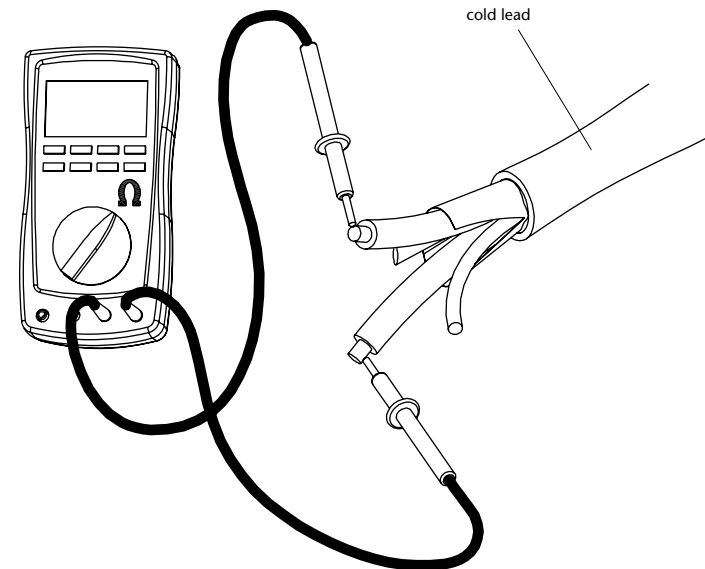

Fig. 2.3

- Write the reading in the measures' table;
- Verify the heating cable integrity by comparing your reading to the value on the cold lead label;
- If your reading is off or very different than the nominal resistance (see Table 2.1) at any step, stop work and contact CELSIAIR INC.'s technical specialists at 1 866 930-7878.

The **Momento Cable** floor heating system can be used for two purposes maximizing comfort.

Used as a secondary heat source (floor warming), it can help keep floor temperature comfortable year round. Used as a primary room heat source (radiant floor heating), it provides uniform, comfortable, and enveloping warmth. For the latter use, it is important to follow the specific recommendations outlined below.

In light of environmental factors beyond CELSIAIR INC.'s control—including thermal insulation, heated area, floor covering emissivity, heat loss, and more—we cannot guarantee that the **Momento Cable** system will provide a completely uniform surface temperature in all cases, no matter how careful the installation. Consequently, CELSIAIR INC. cannot be held liable for any discomfort (e.g., a cold area on the floor) caused by site-specific deficiencies. CELSIAIR INC. liability is limited to the performance of its products.

### 3.1 Floor Warming

This type of heating is designed to enhance comfort and/or supplement the room's main heat source. It helps keep the floor at a pleasant temperature at all times.

Installing this type of system is very easy: simply unroll the **Momento Cable** on the floor, maintain it with the installation strappings, embed the heating cable in cement or an equivalent binder (cement glue, ceramic glue, self-levelling cement) and install the floor covering. Use the floor coverings listed in Section 3.3 and connect the **Momento Cable** system to an appropriate thermostat, described in Section 5.

### 3.2 Radiant Floor Heating

**Momento Cable** can be used as the room's primary heat source. It can heat the room using the **Momento Cable** system only. Proceed as follows:

- Connect the system to an ambient temperature regulator;
- Calculate heat loss to ensure the system has enough power to heat the room;
- Sufficient insulation under the subfloor is very important. This insulation is to be sure that the heat will rise into the room to be heated.
- Make sure to have a floor covering that meets the specifications listed in Table 3.3.



#### IMPORTANT!

**Do not install a radiant floor heating system on a noninsulated or poorly insulated subfloor, or over a crawl space.**

**The efficiency of this type of primary room heating system will depend on factors such as available surface of the room to be covered with heating cable (or sufficient percentage of the surface to be heated), heat conductivity of the floor covering, insulation on outside walls, etc. We recommend that you verify these points and seek professional advice before investing time and money.**

### 3.3 Typical Floor Coverings



#### IMPORTANT!

**The thermal resistance of the floor covering must not exceed R = 1.40 (RSI = 0.246). There is no such limit for the subfloor.**

Table 3.3 Thermal resistance values for floor coverings

Typical floor covering	Thermal resistance	
	R	RSI
Vinyl tiles	0.20	0.035
Linoleum	0.22	0.039
Ceramic	0.25	0.044
Low-pile carpet	0.70	0.123
Parquet flooring	0.70	0.123
Floating floor 10 mm to 16 mm (3/8" to 5/8")	0.70	0.123
Wood on lathes (strapping)*	2.10	0.368

\* The floor covering highlighted in grey is prohibited.



#### IMPORTANT!

**For engineered wood floorings, laminated hardwood flooring, vinyl coverings, and linoleum glued to a concrete surface, consult your floor covering manufacturer to ensure they are compatible with floor heating systems.**

### 4.1 Planning Work

#### Materials provided by CELSIAIR INC.

- **Momento Cable** heating cable kit
- Installation strappings
- Installation instructions
- Service panel label
- Floor temperature sensor

#### Material required

- Temperature control with GFCI (available at CELSIAIR INC.)
- Cable check tester (available at CELSIAIR INC.)
- Stapler
- Protective glasses
- Measuring tape
- Broom
- Felt marker
- Tape
- Hot glue gun
- Wood chisel
- Hammer
- Multimeter and megohmmeter
- Electrician tools
- Electrical tape

#### For installation over a concrete slab, add the following:

- Concrete chisel
- Drilling machine
- Percussion drill for concrete

#### Room Layout and Corresponding Momento Cable Product

- Create a room layout plan to scale (for maximum accuracy, use the CELSIAIR INC. form designed for this purpose);
- Identify all stationary elements (toilet, bath, shower, counters, drawers, and permanent furnishings) and never install the heating cable under these stationary elements (Fig. 4.1);
- Determine thermostat or temperature control location;
- Note room dimensions;
- Determine the electric cable (cold lead) location that will be connected to the heating control;
- Calculate the heating area in square meters (sq. m) [square feet (sq. ft.)];
- Select the **Momento Cable** product from Table 2.1 to cover 80% of the surface, or subtract a minimum of 50 mm (2 in) around walls and stationary elements.

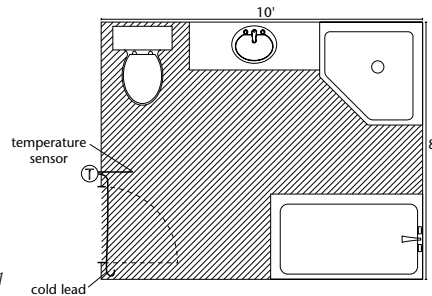

Fig. 4.1



We can help optimize your work plan.

Fax it to us at 418-663-7267. Clearly indicate all dimensions.

A minimum of one horizontal and one vertical dimensions are necessary to validate the scale.

### 4.2 Preparing the Subfloor

- Clean and remove any debris, or protruding objects that could damage the heating cable;
- Subfloor cracks must be filled with polyester wood filler (only for self-leveller);
- The subfloor must be solidly fastened in place to prevent movement;
- The application of a floor levelling product is recommended to prevent future damage to the ceramic caused by subfloor movement;
- For concrete subfloors, apply a surface sealer that is compatible with electrical heating systems in accordance with the cement glue manufacturer's instructions. Completely coat the surface;
- Let dry before installing the **Momento Cable** system (refer to the sealer's instructions for drying time).

### 4.3 Marking the Floor



Felt marker

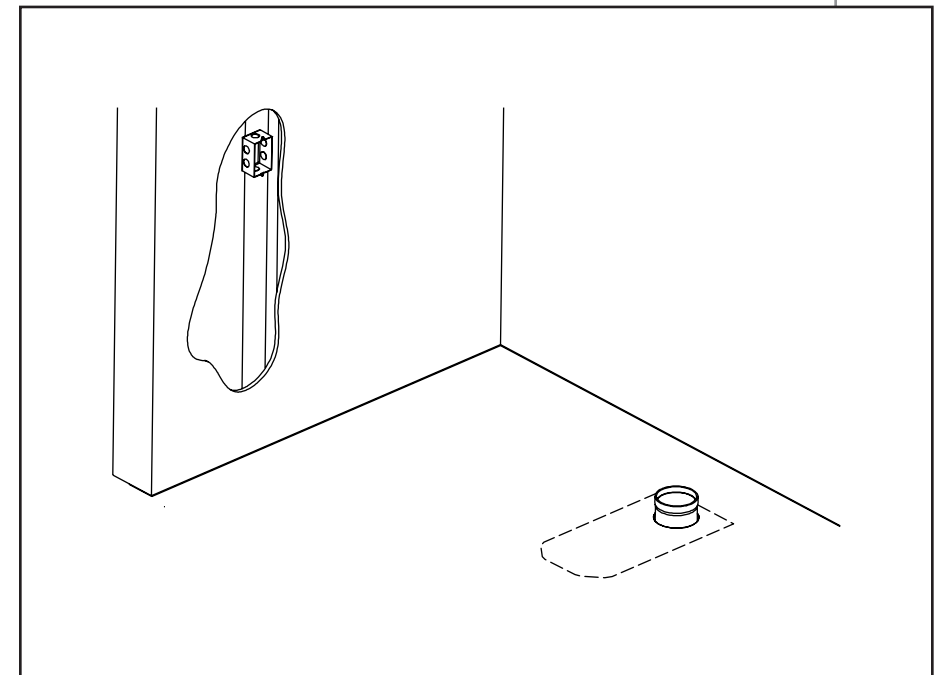

Fig. 4.3 a

- On the floor of an empty room (under construction or major renovations), draw the location of stationary elements (toilet, bath, shower, counters, drawers, permanent furnishings) that will be installed later. These marks will outline the heating area to ensure the **Momento Cable** system is not placed under these stationary elements.
- The floor temperature sensor must be centered between two parallel heating cables. The ideal location is one where it is likely to be away from stationary objects and sheltered from outside influences (sunlight) that could skew floor temperature readings. For maximum comfort, the area above the sensor must be free of obstruction.

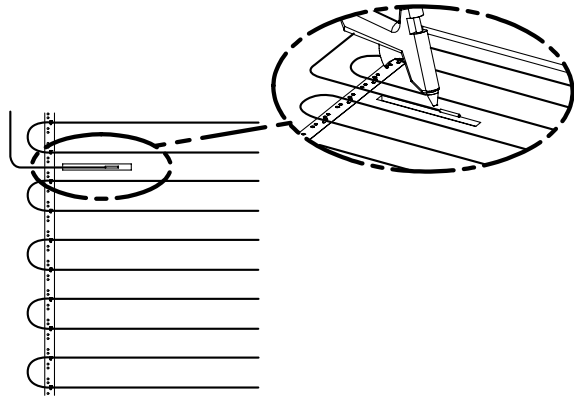

Fig. 4.3 b

#### 4.4 Installing the Momento Cable Floor Heating System

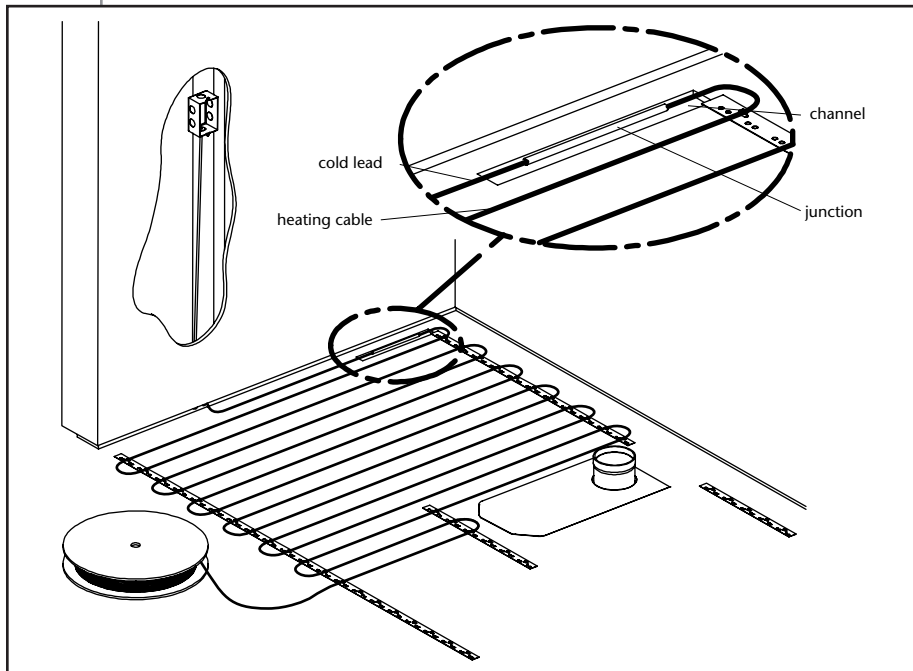



Fig. 4.4 a

 Tape, hot glue gun, stapler

 Remove the product from the box and verify the electrical and insulation resistance of the heating cable.

#### Momento Cable strappings' installation:

- The strappings are fixed on the floor with staples (T50) (when the floor is made of plywood or wood) or with a hot glue gun.
- The strappings must follow the outline draw on the room layout (Section 4.1)
- If the lacing distance between two strappings is over 0,625 m (2 ft.), it is necessary to place an intermediate strapping to maintain the cable in position during the pouring of self-leveller, this strapping is installed at the end, after the lacing of the cable.
- The cable can be installed under the ceramic tile of a shower or other wet surfaces, the strappings and the heating cable must be glued **under the under the waterproofing membrane** and not stapled, staples could damage the waterproofing membrane.

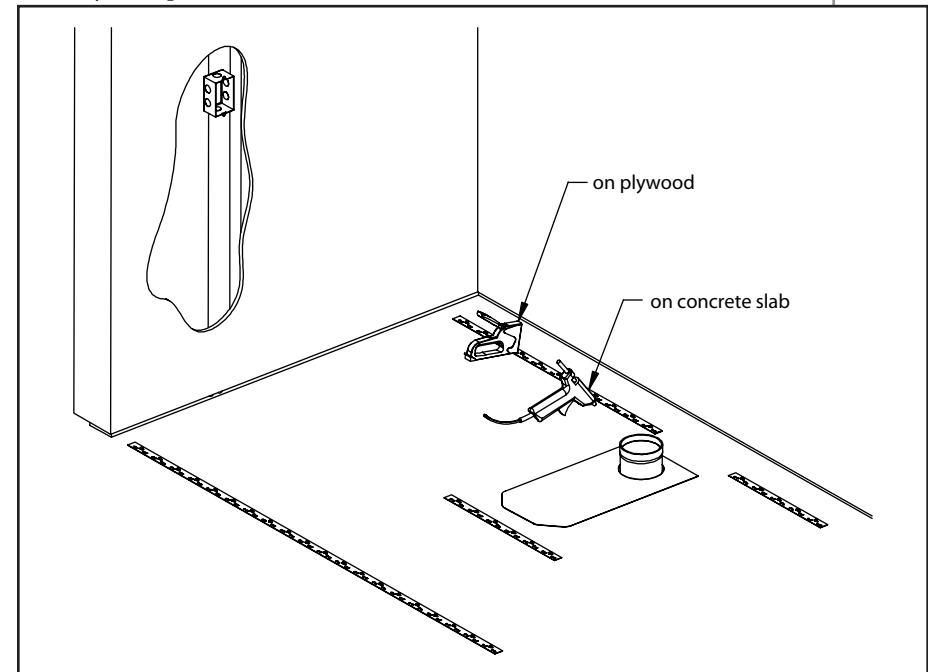

Fig. 4.4 b

#### Installation of Momento Cable

- Set the cable near the connection box and regularly lace the heating wire respecting the distance between the sections; 76 mm (3").
- Do not bend the cable at 90° when setting it in the strapping hooks; leave a 20 mm (3/4") radius. This radius comes naturally; the cable must not be forced to have a tight bend.

- A tag is located at 50% of the cable length. During installation of the product, verify the cable half tag to compare with your cable layout planification. Adjust pattern with the result to cover the surface. If the cable is too long, use the buffer zone to spend the remaining cable. **Never shorten the heating cable.** The heating cable must not be shortened, neither cut.
- Avoid walking on the **Momento Cable** system. If you must, wear soft rubber soled shoes;
- **Always start the Momento Cable at least 50 mm (2") from the walls;**
- It is important not to subject the heating cable to any mechanical strain (stretching, bending radius under 20 mm [3/4"], scoring).

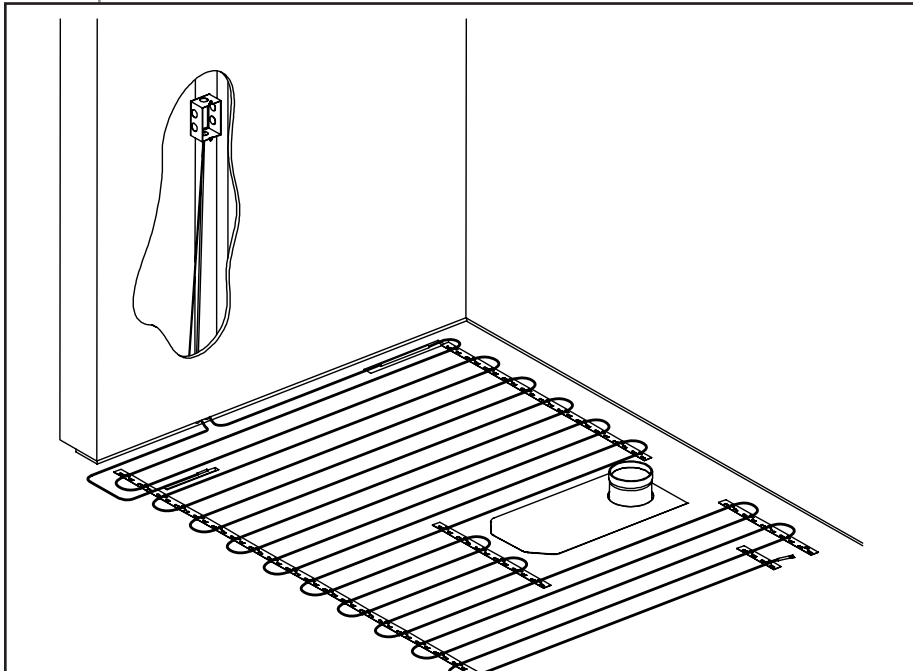

Fig. 4.4 c

**IMPORTANT!**

Never cut or score the heating cable.



Measure the cable's electrical and insulation resistance and record the readings on line 2) After installing the heating cable of the measures' table.

#### 4.5 Installing the Temperature Sensor



Hot glue gun, hammer, wood chisel or concrete chisel

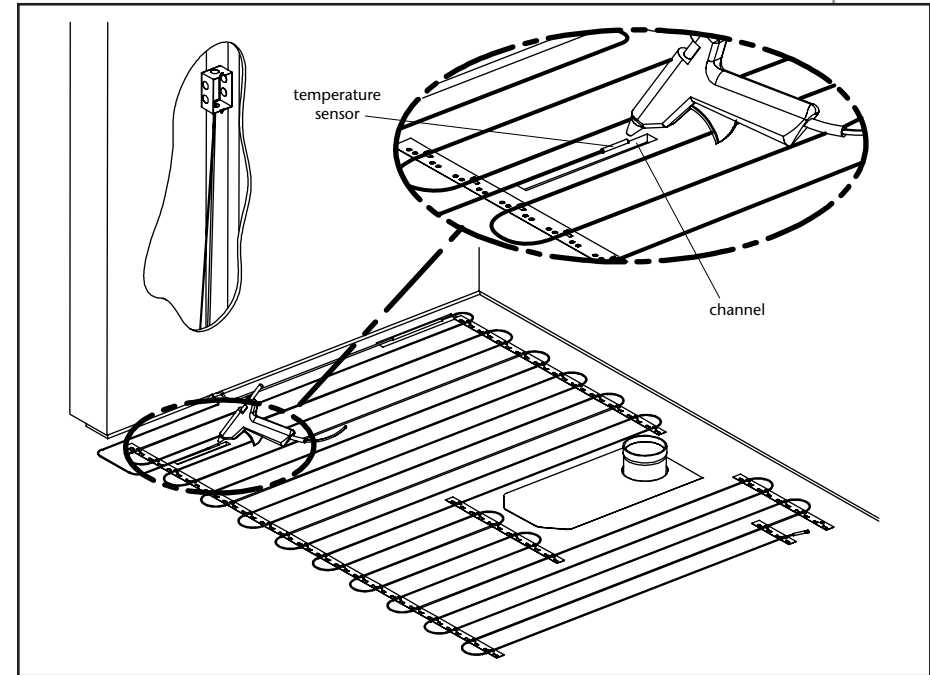

Fig. 4.5 a

- To minimize floor height, chisel a 10 mm X 10 mm X 250 mm (3/8" X 3/8" X 10") channel in the subfloor to receive the floor sensor. The junction has an insulation sheath and a slightly larger diameter than the heating cable.



**IMPORTANT!**

The sensor must be embedded in cement or an equivalent binder (cement glue, ceramic glue, self-levelling cement).

- Glue the sensor to the subfloor (Fig. 4.5). The sensor must be solidly fastened to the subfloor to ensure it stays in place when the cement or an equivalent binder (cement glue, ceramic glue, self-levelling cement) is applied.

#### 4.6 Applying Self-Levelling Cement

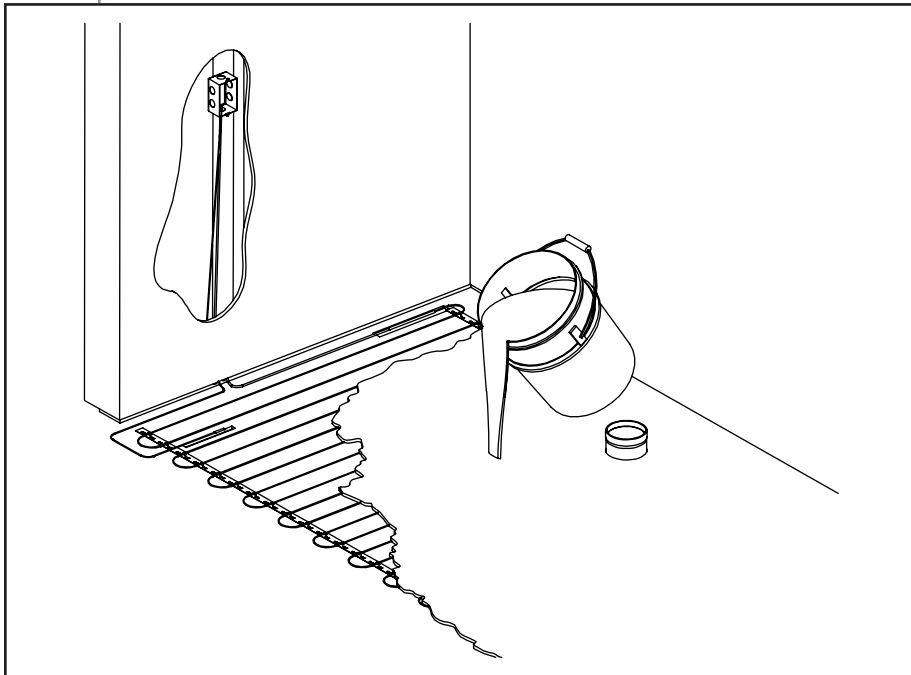

Fig. 4.6



Measure the cable's electrical and insulation resistance and record the readings on line 3) *Before embedding the heating cable in self-levelling cement of the measures' table.*

- Consult the manufacturer's instruction for the type of floor covering (ceramic, linoleum, or other). See Section 7, "Expert Tips";
- Completely embed the heating cable in self-levelling cement (Fig. 4.6). It is crucial that the ENTIRE heating cable (BLACK) be embedded. No part of the heating cable (BLACK) must be exposed. (A small part [top] of the heating cable may be exposed at the surface of the self-levelling cement ONLY IF a ceramic glue is used afterward AND embeds that part);
- Level the subfloor with self-levelling cement or cover the cable with a layer of cement glue when installing the stones or ceramics.



#### IMPORTANT!

**Do not turn on the Momento Cable floor heating system before the cement has completely dried. Follow manufacturer recommendations (may take up to 30 days, depending on the product).**



Once the cement or binder has dried, measure the cable's electrical resistance and record the readings on line 4) *After embedding the heating cable in cement of the measures' table.*

#### Final view

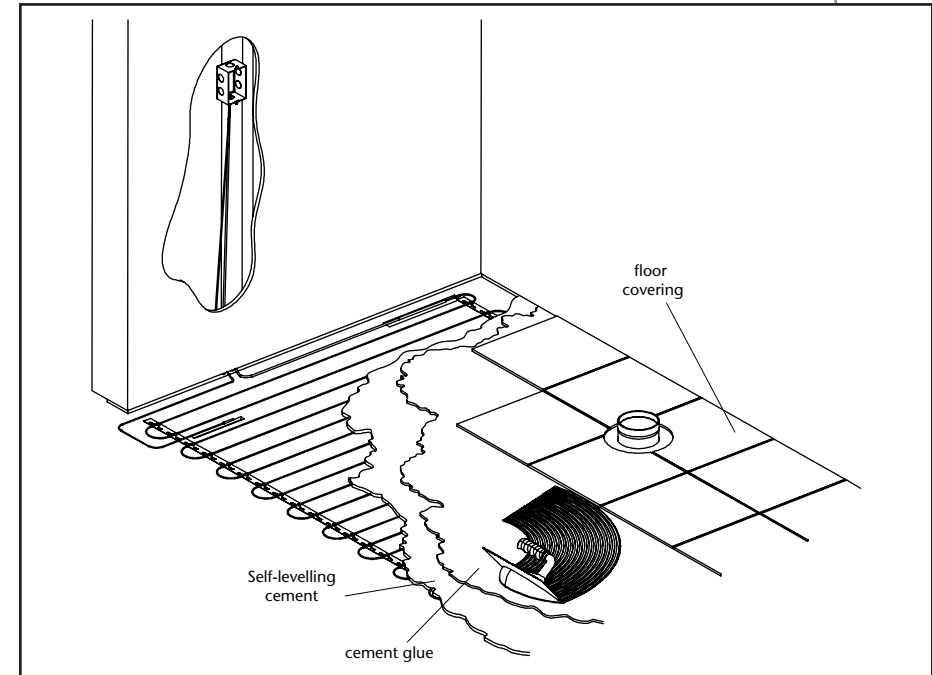

#### 4.7 Connecting the System



#### IMPORTANT!

**The system must be connected by a master electrician.**

#### Cold lead

- 240V/208V connection:  
Line 1-Black  
Line 2-Red  
Bare wire-ground

- 120V connection:  
Line-Black  
Neutral-White  
Bare wire-ground



Measure the cable's electrical resistance and record the readings on line 5) *Upon installing the thermostat of the measures' table.*

#### 4.8 Measuring Resistance and Measures' table

- The master electrician who installed and connected the **Momento Cable** system must complete the measures' table (this label is available at the opening of the product) and give it to the customer. This sheet must be kept near the electrical service.



#### CAUTION!

If this table is not duly completed, the warranty may be annulled. Warranty terms are set out in Section 8.

---

#### 4.9 Using the Momento Cable System

- The **Momento Cable** floor heating system is now ready for use. However, before turning on the system, make sure the curing period specified by the cement or binder manufacturer has expired. Adjust the thermostat's temperature based on your needs and desired level of comfort.

#### 5. IMPORTANT!

The **Momento Cable** system must be controlled by a temperature control system.

If **Momento Cable** is to be used for floor warming, an electronic floor temperature control featuring a floor sensor is recommended to ensure heat levels never exceed the floor covering's maximum temperature tolerance.

If the system is to be used for radiant heating, the room thermostat controls heat and is reacting to room and not floor temperature therefore a floor covering with greater temperature resistance must be used.

The room temperature control and floor temperature sensor must never be installed where they will be exposed to sunlight or air drafts.

---



#### IMPORTANT!

The **Momento Cable** floor heating system must be connected to a ground fault circuit interrupter (GFCI) when installed in a bathroom. CELSIAIR INC. strongly recommends the use of a GFCI in all rooms featuring the **Momento Cable** system.

Recommended temperature regulation devices:

- 1- Thermostat with floor sensor and integrated GFCI (floor warming only).
  - 2- Rheostat dimmer switch with a GFCI.
  - 3- Electronic ambient thermostat with a GFCI (radiant room heating).
-

## 6.1 Floor Heating System

### Q.1: Can I cut the **Momento Cable** heating cable to shorten it?

A.1: NEVER. If the **Momento Cable** is too long, spread it on the floor in regular loops. Keep the minimum distance from the walls and between parallel runs of cable (radius bending of at least 20 mm [ $\frac{3}{4}$ "] for loops). Be sure to keep 76 mm (3") (other spacing option: 100 mm [4"]) between each heating cable loop.

### Q.2: What should I do before choosing the **Momento Cable** system that's right for me?

A.2: Sketch a plan to determine the surface area. We can help optimize your work plan. Fax it to us at 418-663-7267.

### Q.3: How do I repair **Momento Cable** in case of a malfunction?

A.3: First, as a PREVENTIVE measure during installation, test the cable each time as specified in the installation guide. Also complete the measures' table. However, in case of a malfunction, an authorized CELSIAIR INC. repair person will visit to LOCATE the fault and REPAIR it. It is recommended that you keep spare ceramic tiles or flooring for this purpose.

### Q.4: Are there other watt densities per square foot available?

A.4: CELSIAIR INC. believes that 12W/sq. ft. (130W/sq. m) at 76 mm (3") spacing is the best watt density to optimize comfort and prevent floor overheating. **Momento Cable** can also be installed with a 100 mm (4") spacing for a 9W/sq. ft. (96W/sq. m). Moreover, the 240V and 120V systems provide equal heating power per square foot.

### Q.5: Can I crisscross, overlap, or touch two heating cables together?

A.5: NEVER. This will cause overheating. Keep cables at least 76 mm (3") or 100 mm (4") apart.

### Q.6: Can the cable be bent 90°?

A.6: Yes, but make sure the radius bending is at least 20 mm ( $\frac{3}{4}$ "). Any bending smaller than this may damage the cable.

## 6.2 Installation

### Q.7: Can I install one **Momento Cable** system on top of another?

A.7: NEVER. The system will overheat. Heating power must not exceed 12W/sq. ft. (130W/sq. m).

### Q.8: Can **Momento Cable** be used for exterior snow melting?

A.8: No. **Momento Cable** is designed to provide comfort and heating in indoor residential applications only.

### Q.9: Is a GFCI necessary?

A.9: A GFCI is required in the bathroom. It is recommended for all other rooms.

### Q.10: Is a floor sensor necessary?

A.10: Yes, to control floor surface temperature so that it does not exceed the floor covering's maximum temperature tolerance. Even if it is not an obligation to use a floor sensor when using the system with an ambient thermostat, CELSIAIR INC. recommends the use of a floor sensor.

### Q.11: Can I connect two **Momento Cable** systems to the same thermostat?

A.11: Yes. You can even connect additional systems provided the connection is parallel and total output does not exceed the thermostat's capacities.

### Q.12: What happens if the voltage applied is the wrong one?

A.12: Connecting a 120V product to a 240V/208V current will overheat the system and lead to an overheating and failure. A 240V/208V product connected to a 120V current will produce virtually no heat. It is therefore very important to connect the right product to the right voltage.

### Q.13: Can **Momento Cable** be installed over concrete?

A.13: Yes. Apply a concrete sealer before installing the **Momento Cable** system. See Section 4.

### Q.14: Can carpet be installed over **Momento Cable**?

A.14: Yes, if the system is completely embedded in self-levelling cement. You can install low-pile carpet over the slab if the carpet's thermal resistance does not exceed  $R = 1.40$  ( $RSI = 0.246$ ).

### Q.15: Can wood flooring be installed over **Momento Cable**?

A.15: Yes, you can install multilayer wood flooring (Engineered flooring), provided its thermal resistance does not exceed  $R = 1.40$  ( $RSI = 0.246$ ).

### Q.16: Is the use of self-levelling cement mandatory when installing ceramic tile?

A.16: If the room is small, an experienced tiler can do a good job without using self-levelling cement, but this method is not recommended. The heating cable must always be completely embedded in cement or an equivalent binder (cement glue, ceramic glue, self-levelling cement). If the room is medium-sized or large, the use of self-levelling cement is strongly recommended to ensure the ceramic is perfectly level.

### 7.1 Installation Tips

- For multilayer wood flooring (engineered floor) or linoleum, it is recommended that you consult the manufacturer to verify whether these floor coverings are compatible with a floor heating system;
- Though unlikely, the floor temperature sensor may need to be replaced. CELSIAIR INC. recommends installing a flexible plastic tube from the sensor to the thermostat on the wall;
- Fasten the cold lead and floor sensor to a concrete subfloor with adhesive (hot glue, tape).

### 7.2 Floor Covering Tips

- It is strongly recommended to coat the subfloor with a sealer before spreading the self-levelling cement (which is very liquid). This is to prevent any leaks under the floor;
- The use of a latex primer on a concrete subfloor is recommended to ensure the self-levelling cement adheres better to the concrete;
- With multilayer wood flooring (engineered floor), applying a minimum 5 mm ( $\frac{3}{16}$ " ) layer of self-levelling cement on the heating cable is recommended. To completely embed the cable in the cement or cement glue;
- It is important to respect the drying times recommended by the manufacturer to prevent residual moisture from affecting the adherence of floor coverings such as vinyl, linoleum, or wood.

### 8.1 Warranty Statement

Subject to the legal warranties relating to quality and durability of goods provided for by the Consumer Protection Act:

CELSIAIR INC. warrants the **Momento Cable** heating cables (CAR) of its floor heating system for a 25-year period beginning from the date of purchase, against any malfunction or manufacturing defect.

#### Limitations and exclusions

The above mentioned warranties are restricted to the reimbursement of the original purchase cost and replacement of the heating cables and/or defective thermostat (hereinafter the "equipments") excluding any other part also excluding any cost or any expense relating to the connection, removal, installation or fixing of the aforesaid equipments, including workmanship costs.

CELSIAIR INC. leaves the purchaser the care to choose between reimbursement of the purchase cost or replacement of the defective equipments, subject to the abovementioned restrictions.

The present warranties are granted to the original purchaser of the equipments as well as to the subsequent buyer of the building where it has been installed.

#### Terms of warranty

The present warranties are subject to the compliance of the following terms:

- I Purchaser must provide CELSIAIR INC. or an authorized distributor or reseller with the original invoice for the defective equipments;
- II Purchaser must notify CELSIAIR INC., in writing, of any defectiveness with the equipments aimed by the present warranties, in a reasonable time frame from the occurrence or knowledge of the defectiveness and give permission to CELSIAIR INC.'s representatives, the case being, to inspect the defective equipments;
- III The equipments aimed by the present warranties must have been installed in compliance with CELSIAIR INC.'s installation guidelines;
- IV The equipments aimed by the present warranties must have been used in normal conditions and must have been kept under normal maintenance from the purchase date.

#### Name and address of the person granting the present warranty:

##### CELSIAIR INC.

2713 Louis XIV Blvd.  
Quebec (Quebec) G1C 5S9 CANADA

Phone: 418-663-7878 • 1 866 930-7878

Fax: 418-663-7267

info@celsiair.com

**www.celsiair.com**